

# HEADER PROGRAM

## SELECT AND CUT BASE PARTS AND CLAD PARTS

### HEADER SIZE

Select Header Size Listed on Order. 150" (3810 mm) Long.

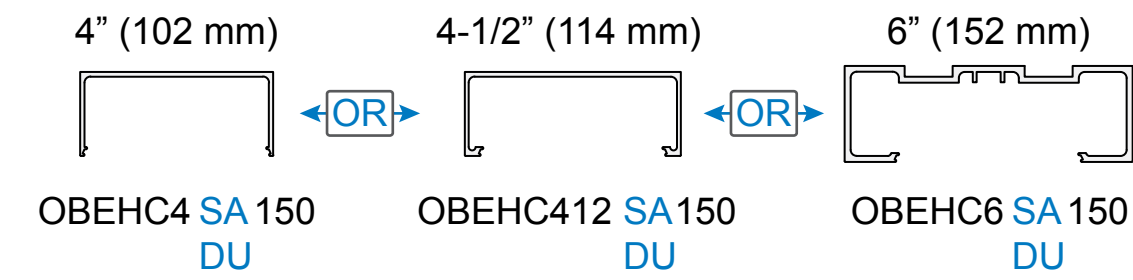

### HEADER CLAD

Select Clad for Header Size. 150" (3810 mm) Long. Cut 2 Pieces Clad to Header Length. NOTE: Flat Shown, Return Available Upon Request.

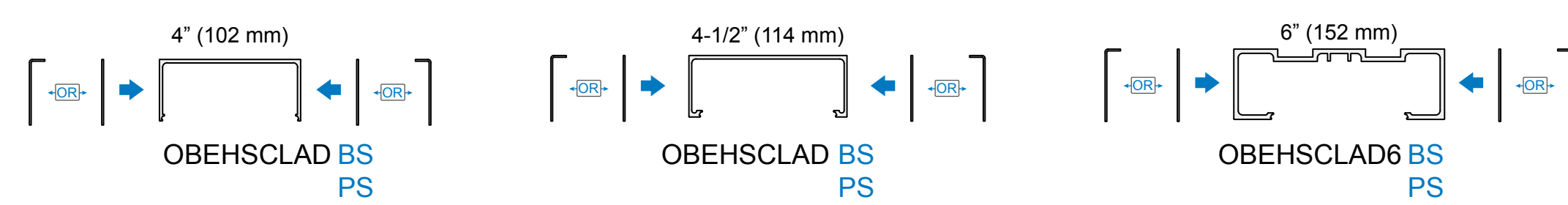

### FLAT SNAP IN OR HARDWARE INSERT

Use with All Header Sizes at Door Area Without Closer or WBP. 150" (3810 mm) Long.



### FLAT SNAP IN OR HARDWARE INSERT CLAD

Select Clad for Header Size. 150" (3810 mm) Long. Cut Clad to Flat Snap In or Hardware Insert Length

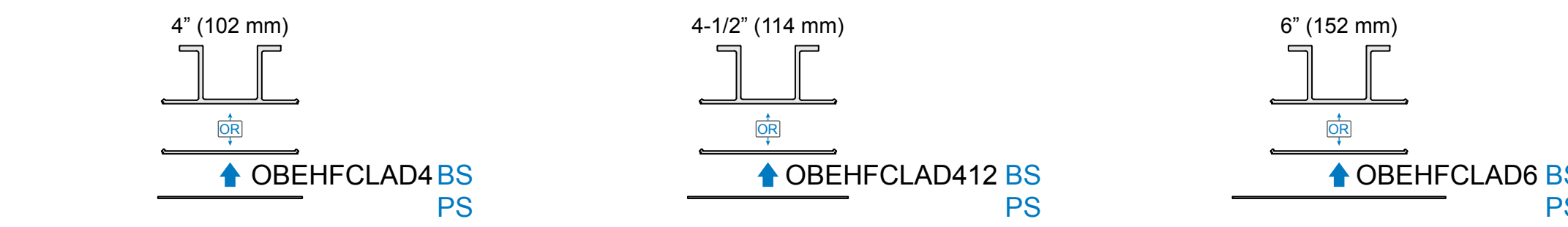

### GLASS POCKET INSERT

Use with All Header Sizes at Sidelites Only. 150" (3810 mm) Long.

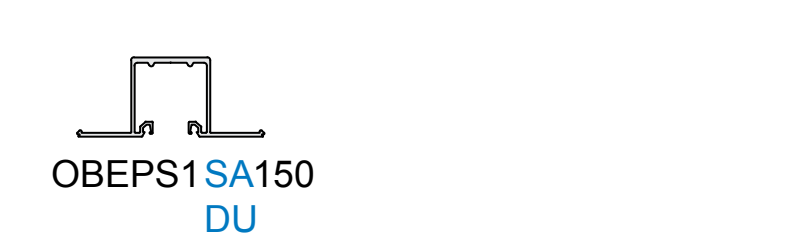

### GLASS POCKET INSERT CLAD

Select Clad for Header Size. 150" (3810 mm) Long. Cut 2 Pieces Clad to Glass Pocket Lengths

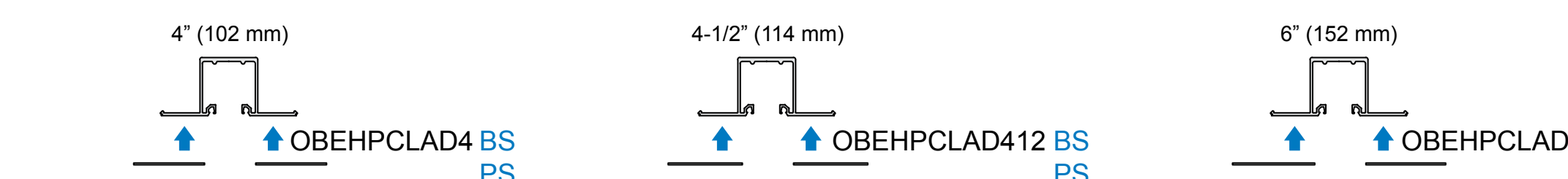

### SNAP IN COVER FOR CLOSER OR CRL WBP

Select Header Size and then Select Model for WBP or Closer Type. Clad is Already Applied.

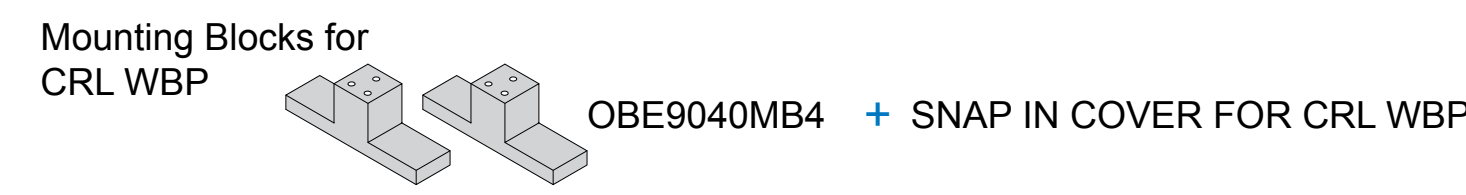
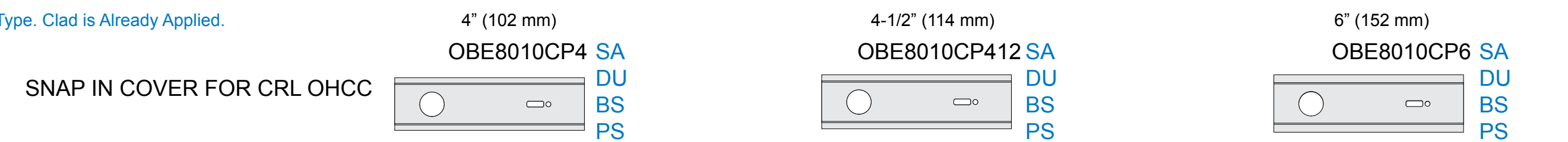

### GLASS POCKET GASKET

Use with All Header Sizes at Sidelites Only. Cut 2 Pieces to Glass Pocket Length.

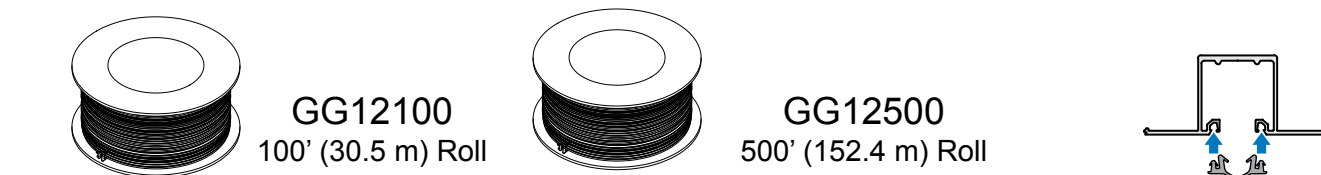

## CALCULATE BASE PART LENGTHS

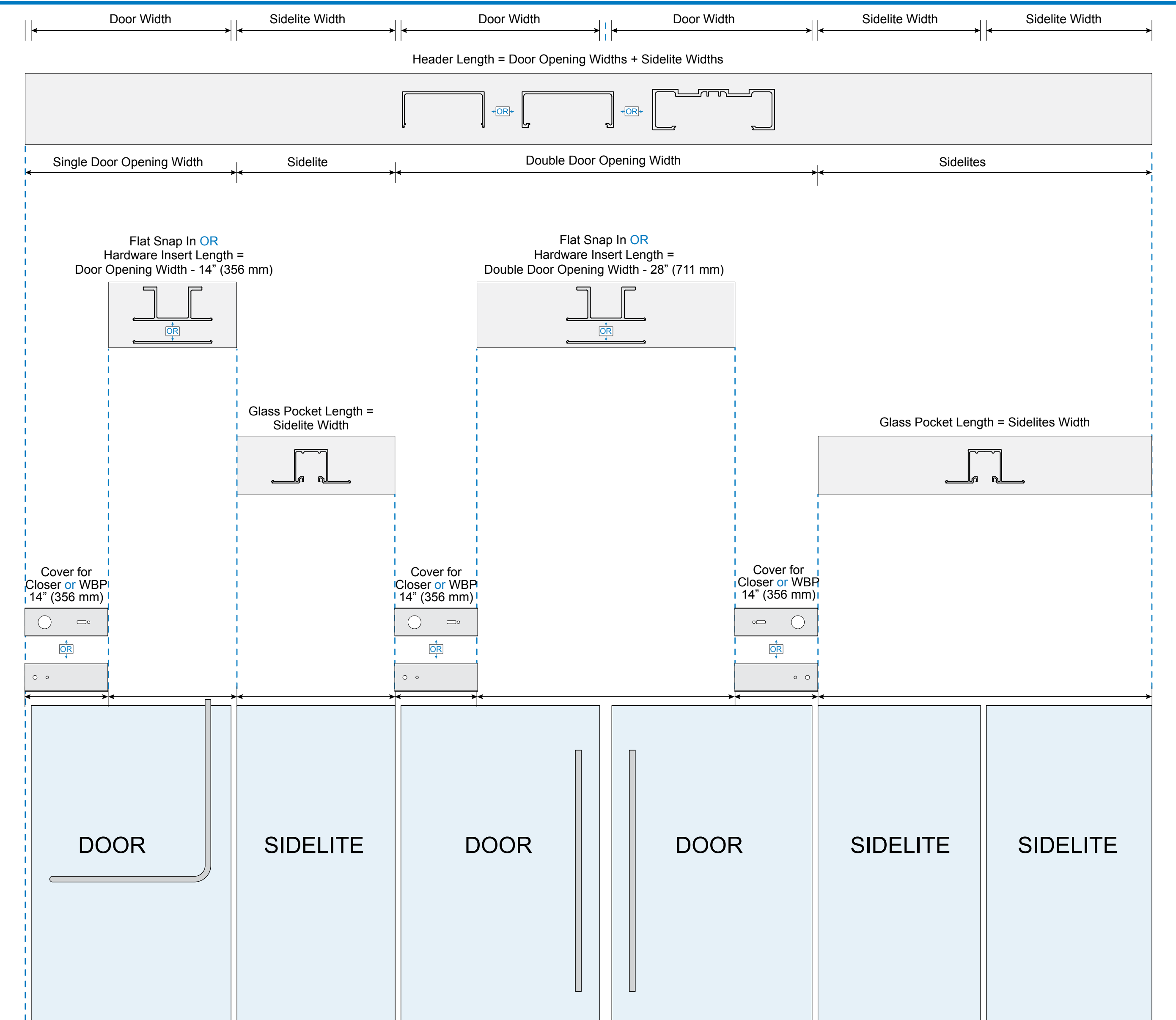

## PREPARE CLADDED UNITS

NOTE: Thoroughly Clean Parts Before Applying Tape. Remove Liner from Side of Tape Applied to Base Part Only.

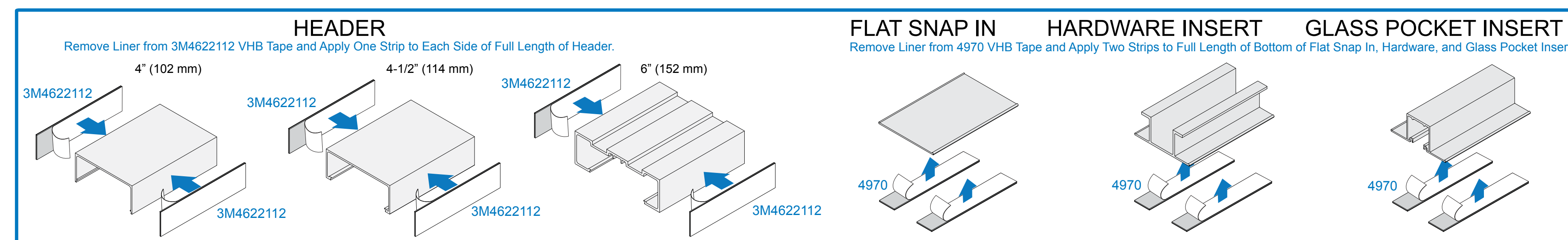

## PREPARE HEADER FOR SNAP IN COVERS

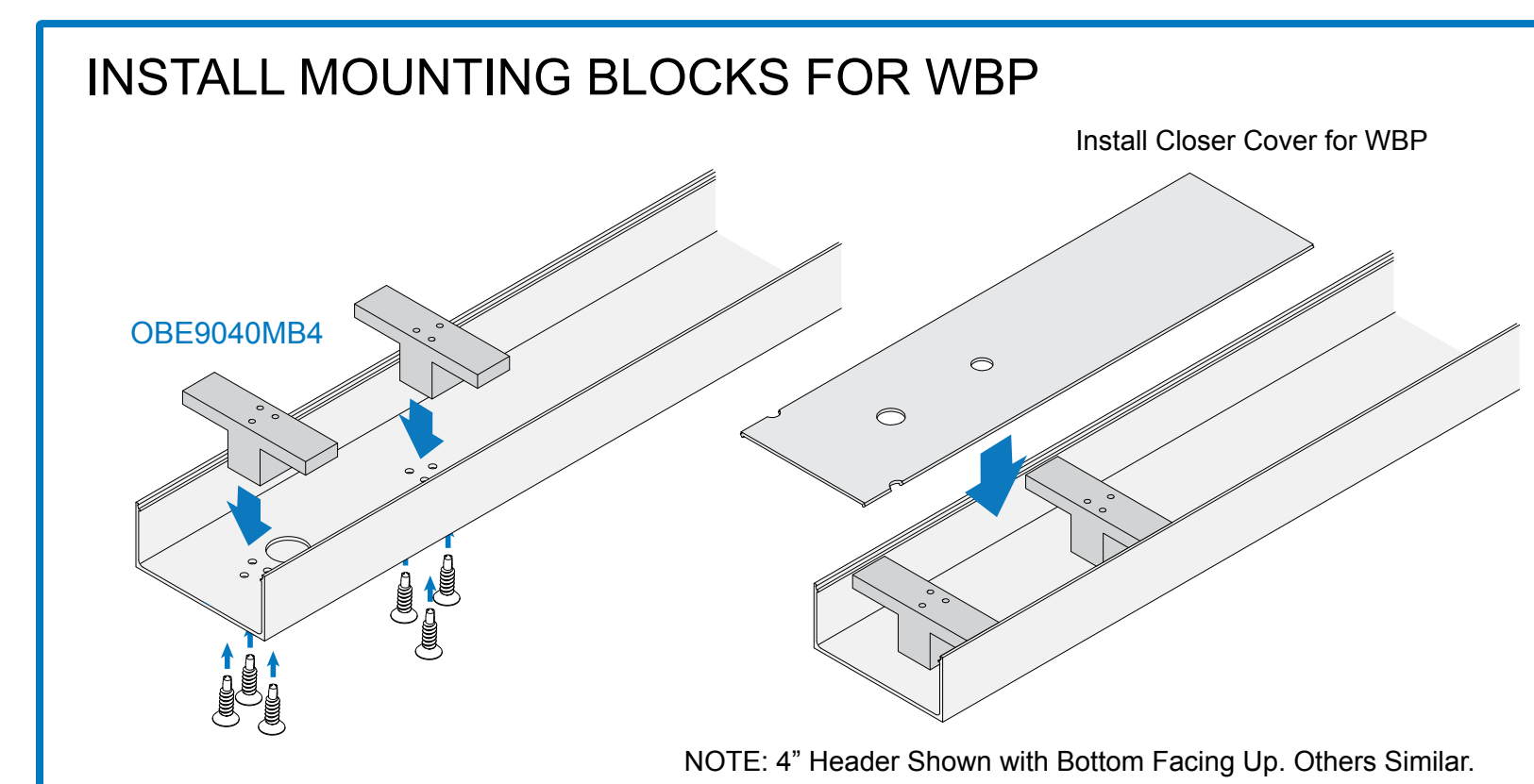
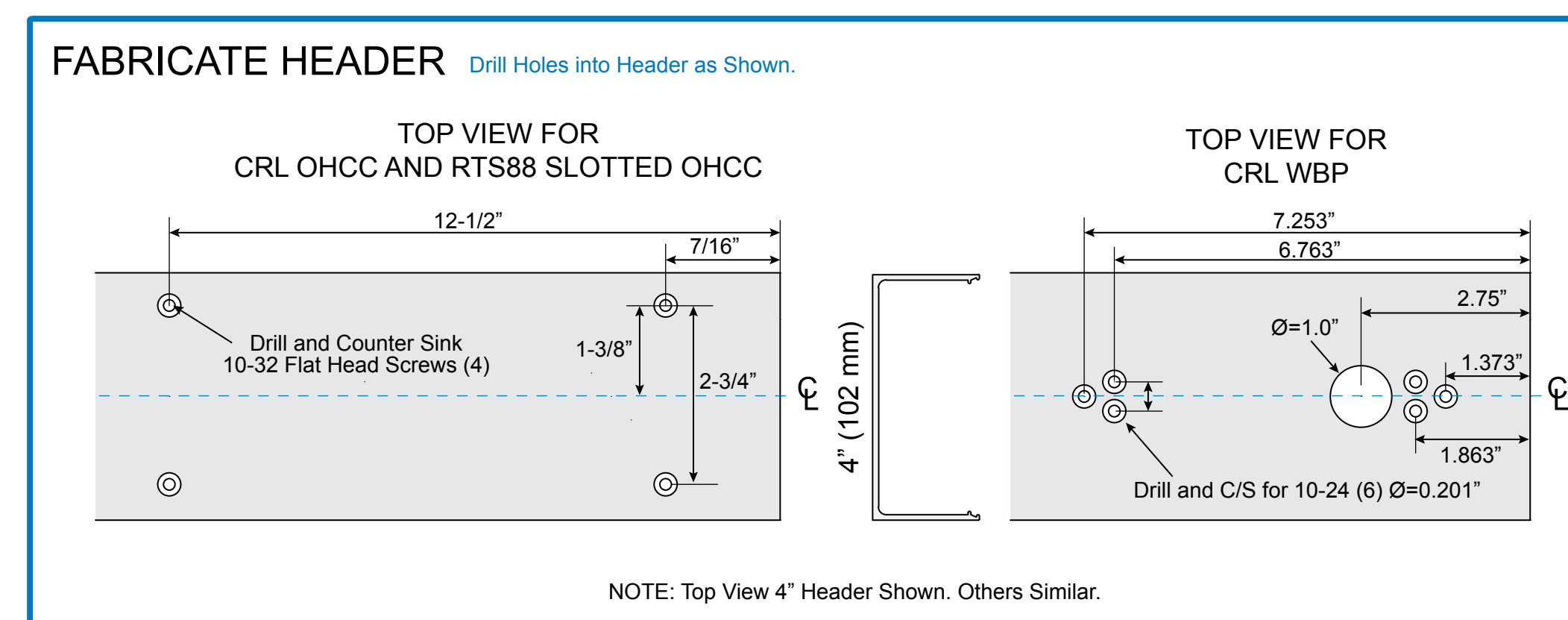

## ASSEMBLE ALL UNITS

NOTE: Cladded Units Have Tape Applied to Base Parts.

